

CBM #10 Series

High Capacity Cash Drawer



Since 1927



Cash Drawers

Options: Model #10 without locks



Alternative lock configurations and alloy locks available.

- The #10 Series is ideal for a large amount of currency. Heavy steel construction and dual storage slides make this an ideal drawer for banks and other financial institutions.
- When you need to store a large amount of currency, CBM offers the ultimate in small business security.

Standard Features

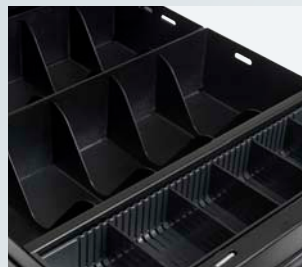

Steel 5 bill tray, and steel 6 coin money tray with removable plastic coin dish for receipt storage



Locking cash and bill lid



CBM #10 Series

High Capacity Cash Drawers

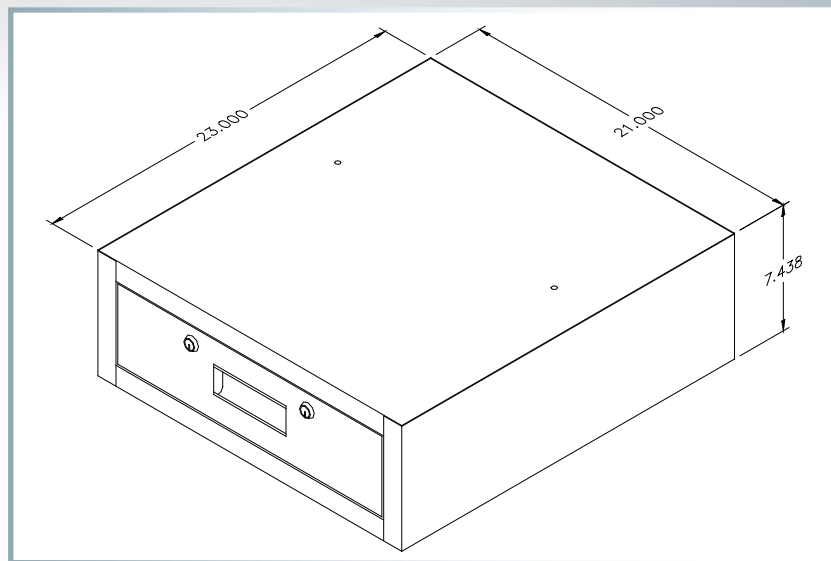

- Top drawer includes one steel #505 Money Tray with removable plastic coin dish for receipt storage and one #507 Bill Tray
- Heavy gauge steel construction
- Dual locks
- Full extension slides

Specifications:

Shipping weight: 58 Lbs (26.3 kg)

Dimensions: 7.438" H x 21" W x 23" D (18.9 cm H x 53.3 cm W x 58.4 cm D)

Tray Components:



#507 Bill Tray



#505 Money Tray



Coin Scoop

Functionality and Dependability

- Additional money trays accessories and locking lids available