

# CBM 2000 Series

Electronic Cash Drawers



Since 1927



Cash Drawers

## Standard Features



Ball bearing slide track system, dual media slots and stainless steel till front



Each unit is equipped with a female RJ style jack in the base of the drawer



Removable #5P plastic money tray with adjustable bill and coin dividers



Key lock (keyed alike available)

## Options & Upgrades

- 12 or 24 volt option
- Cash drawer status switch
- Beige or black powder coat finish



Available in Beige



Available in Black



# CBM 2000 Series

## Electronic Cash Drawers

### Accessories

- Under Counter Mounting Bracket



### Cables



- CBL-2544-B Epson, Y Cable (2 C/D)

### Other Cables Available:

- CBL-2544-A Epson, Citizen 3535 Cable
- CBL-2549 Citizen (Molex) Cable
- CBL-2549-A Citizen Y Cable for IDP 3535
- CBL-2549-B Citizen Y Cable for IDP 3545/46, 3210-CBM 230/231
- CBL-2547-A Star Micronics
- CBL-2547-C Star Micro. Y Cable (2C/D)
- CBL-2531-J1 Ithaca Coax Cable
- CBL-2531-J3 Ithaca 60,80,90,150 Series (Drawer 1)

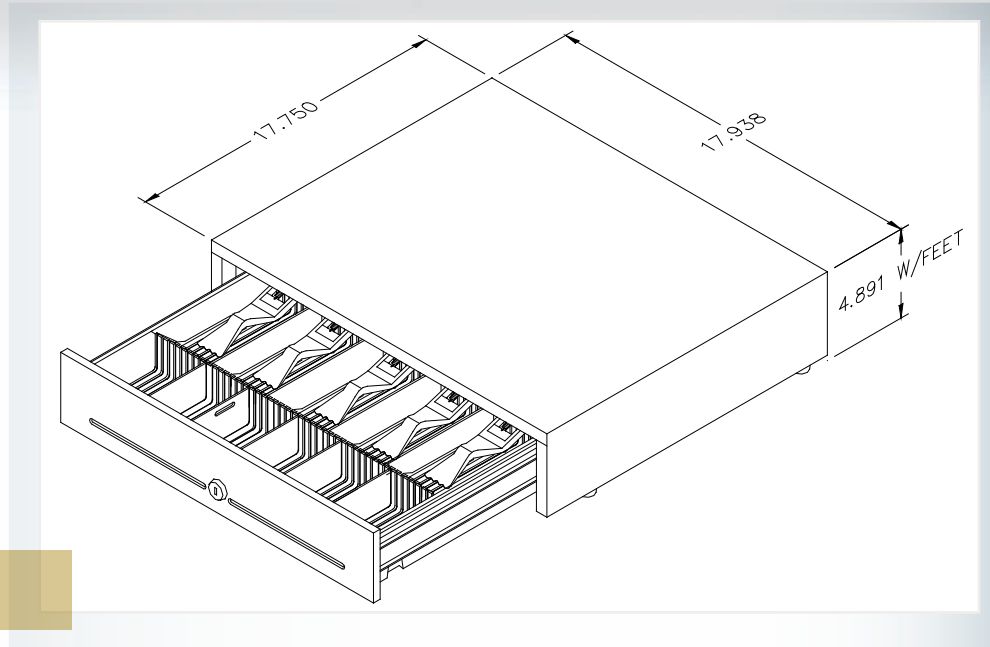

### Functionality and Dependability

- Offers the functionality of a large cash drawer; but with a smaller footprint, allowing you to save valuable counter top space
- Manufactured using 20-gauge cold rolled steel and high quality components.

### Specifications:

Shipping weight: 28 Lbs (12.7 kg)

Dimensions: 4.891" H x 17.938" W x 17.75" D (12.2 cm H x 45.6 cm W x 38.7 cm D)

### Order additional Money Trays and/or Storage Locker



#5P Plastic Money Tray



#5S Steel Money Tray



Cash Tray Locker (# A08046)