

CBM #20 Series

High Capacity Cash Drawer



Since 1927



Cash Drawers

When you need to store a large amount of currency, CBM offers dependable High Capacity Cash Drawers. Which provide maximum storage and durability.

Standard Features



- Push button ganglock, locks both drawers



- Bottom drawer for pre counted currency



- Top drawer has 5 bill tray and 6 coin money tray



- Full extension drawer slides



sales@cbmmetal.com • www.cbmmetal.com • 800.387.4834

CBM #20 Series

High Capacity Cash Drawer

Functionality and Dependability

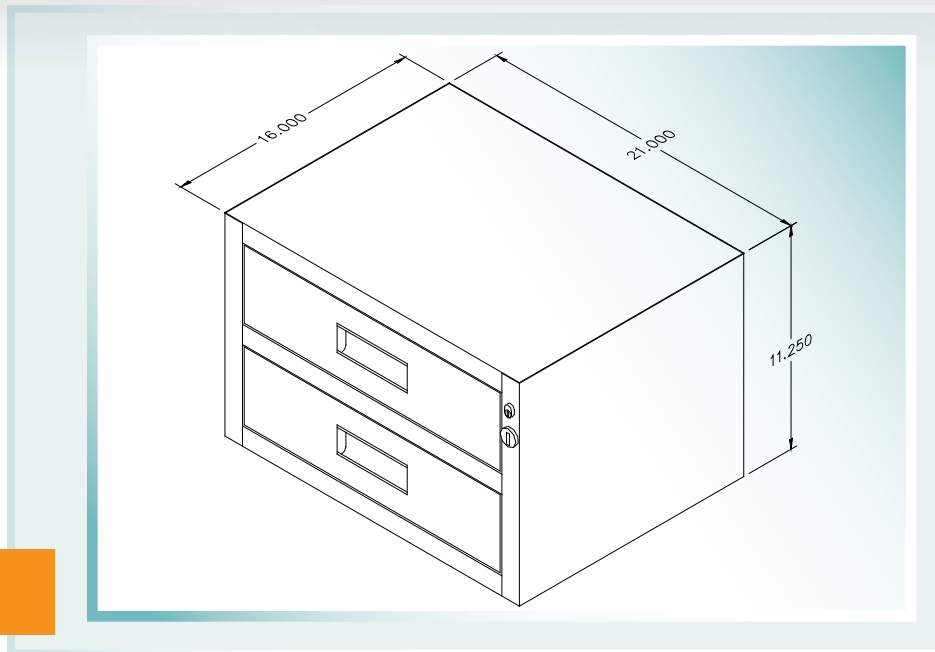

- Top drawer includes one #505 Money Tray, and one #507 bill tray.
- Bottom drawer includes one #508 Money Tray with plastic insert for pre-counted currency or cheque storage
- Locking lid for 5 bill, adjustable coin tray included
- Heavy gauge steel construction
- Push button ganglock, locks both drawers
- Secondary keylock which overrides ganglock control
- 50% more capacity than the #10 Cash Drawer

Specifications:

Shipping weight: 97 Lbs (44 kg)

Dimensions: 11.25" H x 21" W x 16" D (28.6 cm H x 53.3 cm W x 40.6 cm D)

Additional trays may be ordered separately



#505 Money Tray

#507 Bill Tray

#508 Money Tray