

CBM #5 Series

Manual Cash Drawers



Since 1927



Cash Drawers

- The CBM #5 manual cash drawer features five bill compartments and adjustable coin dividers

Standard Features



Key lock
(keyed alike available)



Ball bearing slide track system, dual media slots and powder coated till front



Removable #5P plastic money tray with adjustable bill and coin dividers



Push button drawer release

Options & Upgrades

- High security lock



Available in Beige



Available in Black



CBM #5 Series

Manual Cash Drawer

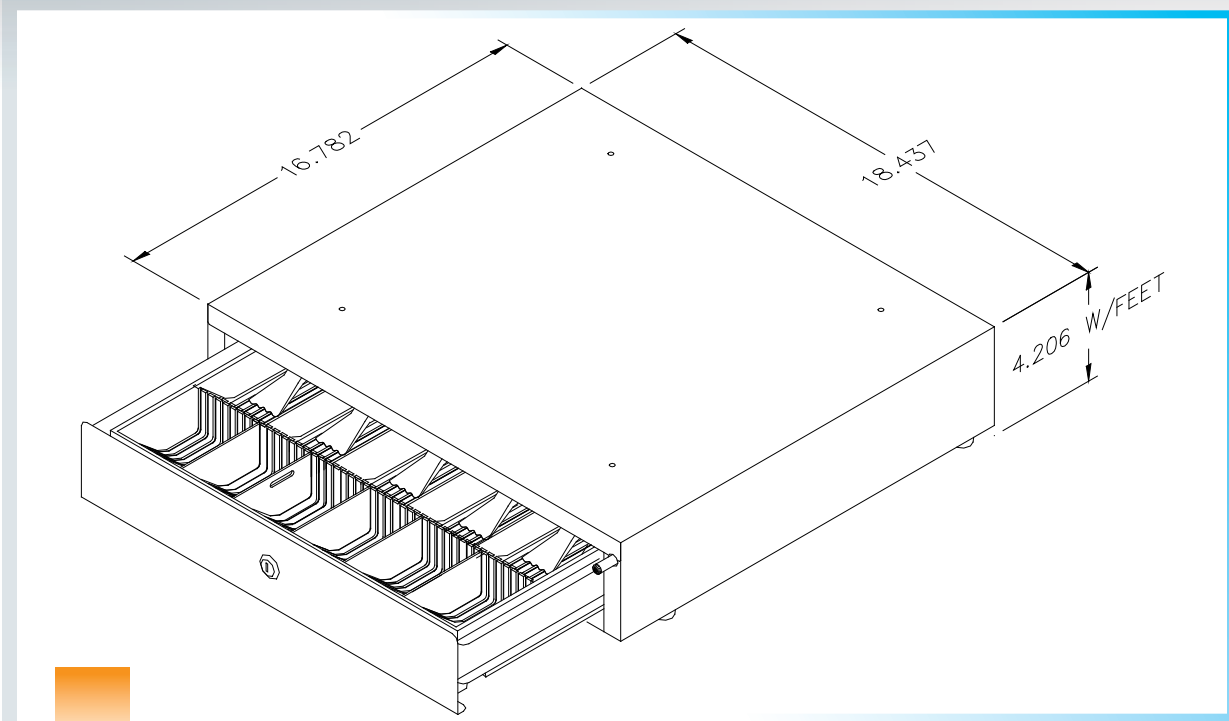

Functionality and Dependability

- #5 manual cash drawer features five bill compartments and adjustable coin dividers

Specifications:

Shipping weight: 26.5 Lbs (12 kg)

Dimensions: 4.206" H x 18.437" W x 16.782" D (10.7 cm H x 46.8 cm W x 42.6 cm D)

Order additional Money Trays and/or Storage Locker



#5P Plastic Money Tray



#5S Steel Money Tray



Optional Cash Tray Locker
Cash Tray Locker (#A08046)



Optional Locking lid for
#5 Adjustable Money Tray