

PSC-1

Projector Security Cage

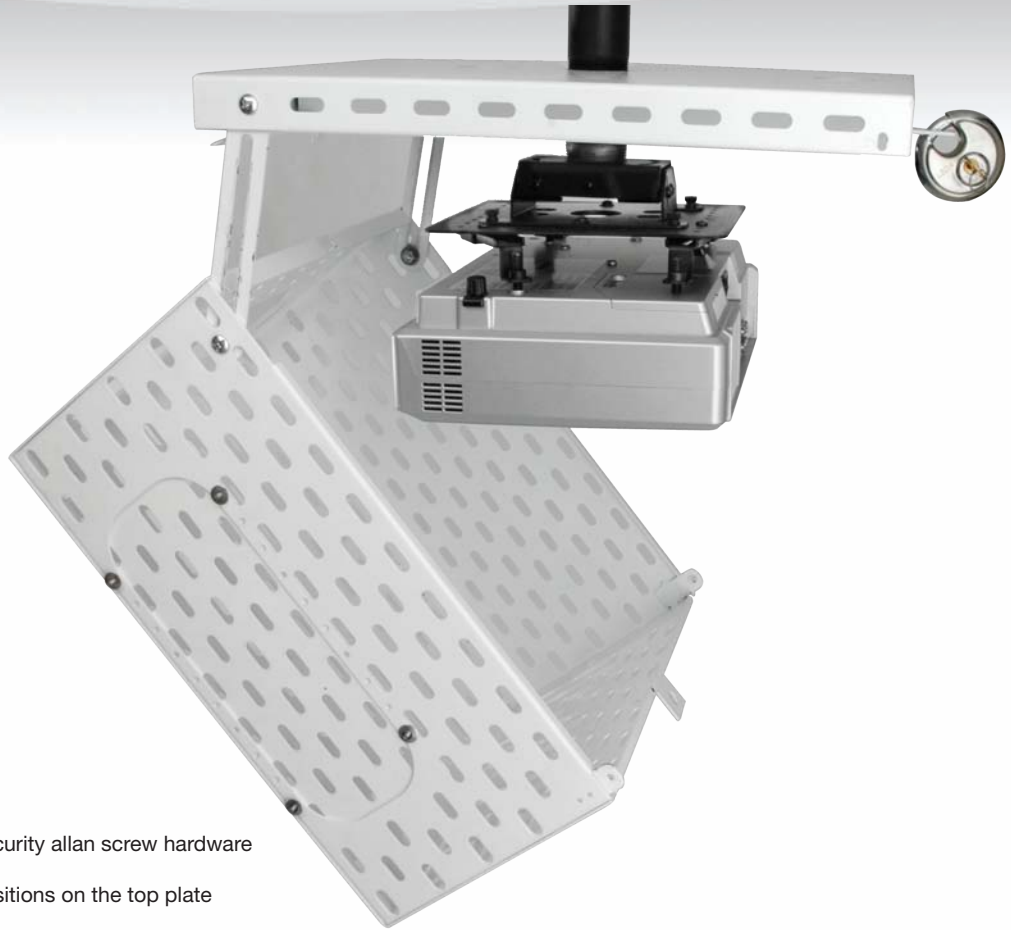

Since 1927



Audio Visual

Standard Features

- Heavy gauge construction with security allen screw hardware
- Welded 1 1/2" coupling in two positions on the top plate
- Front and side openings provide optional mounting positions
- Cable management hole in top plate
- Unit swings down for access to LCD projector
- Perfect for one person maintenance and bulb replacement
- Fully assembled
- Pipe and UPRO-1 sold separately

Protect your investment with a reliable
LCD Projector Security!



Highest quality pad lock security



Provides excellent air circulation



sales@cbmmetal.com • www.cbmmetal.com • 800.387.4834

PSC-1

Projector Security Cage

PSC-1

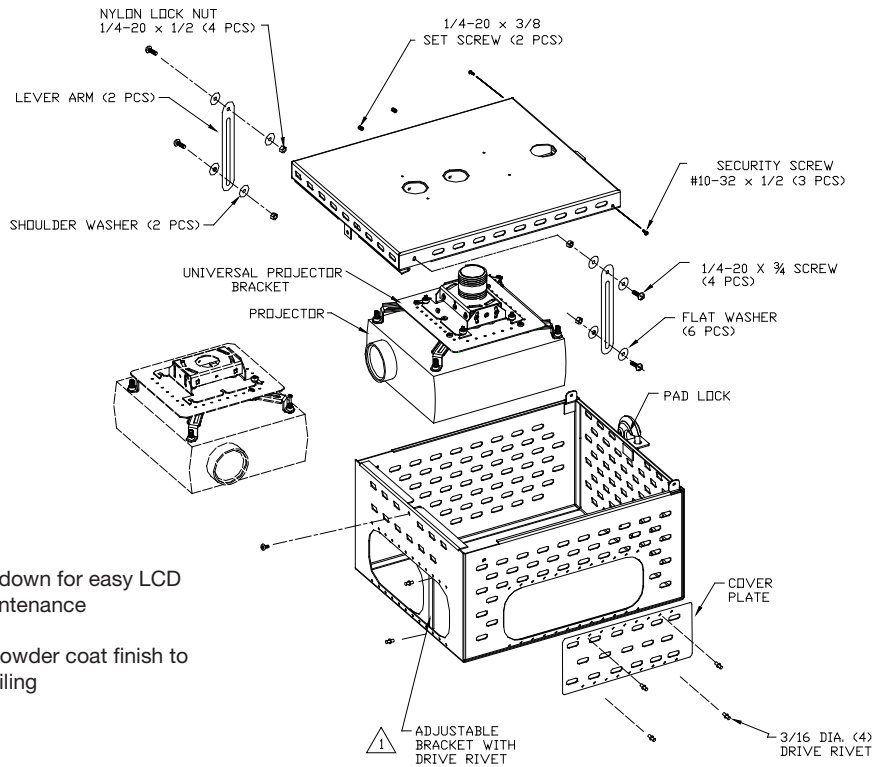

- Cage swings down for easy LCD Projector Maintenance
- Matte white powder coat finish to match any ceiling

Reliable LCD Projector Security

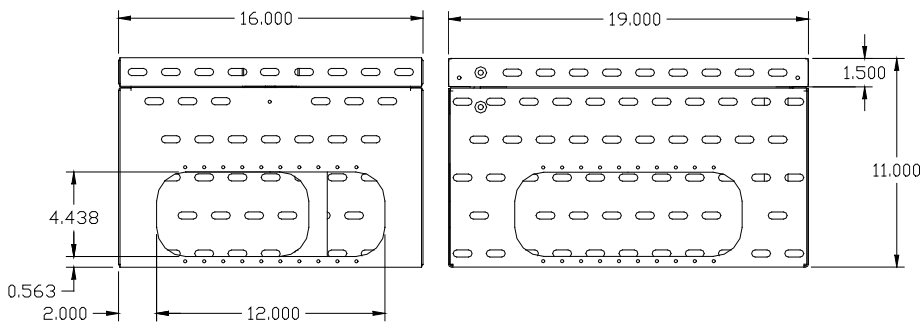

- Heavy duty pad lock security included
- Fits scrambler and turret LCD universal projector mount

Components:

- Top cover weldment
- Body and cover plate
- Adjustable brackets
- Lever arm (2 places)

Specifications:

Shipping weight: 35 Lbs (15.9 kg)

Dimensions: 19" L x 16" W x 11" H
(48.3 cm L x 40.6 cm W x 27.9 cm H)
Maximum load: 50 Lbs (22.7 kg)

* 12 Month Full Satisfaction Guarantee *

CBM Ltd. Guarantees its products against failure or defects for a period of one year from date of purchase. This warranty is void if any damage to the product is due to misuse, abuse, neglect, accident, improper installation, or any uses contrary to the instructions accompanying the product. The foregoing are the purchaser's exclusive remedies CBM Ltd. Assumes no liability for special or consequential damages. Replacement product may be obtained by returning the product, transportation charges prepaid, together with a receipt of purchase or other documents acknowledging the sale.