

High Capacity Money Trays



Ideal for use in the CBM high capacity series cash drawers and is suitable for various teller unit applications.



Money Trays

Model #508, #507

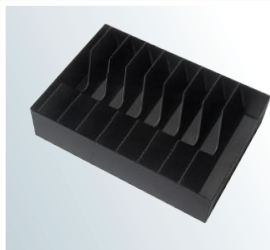

Model #508

8 compartment tray
Shipping Weight:
6 lbs (2.7 kg)
Dimensions:
Height: 3.625" (9.2 cm)
Width: 15.75" (40 cm)
Depth: 11.25" (28.6 cm)



Model #507

5 compartment tray
Shipping Weight:
4 lbs (1.8 kg)
Dimensions:
Height: 3.625" (9.2 cm)
Width: 15.75" (40 cm)
Depth: 6.5" (16.5 cm)

Model #505



Model #505 Features

- 5 bill compartments.
- Tray is deep enough to allow for receipt storage.
- Compatible with #20, #10 and all CBM teller units.
- Removable coin scoop.
- Adjustable plastic coin dividers.



sales@cbmmetal.com • www.cbmmetal.com • 800.387.4834

High Capacity Money Trays

Model #505

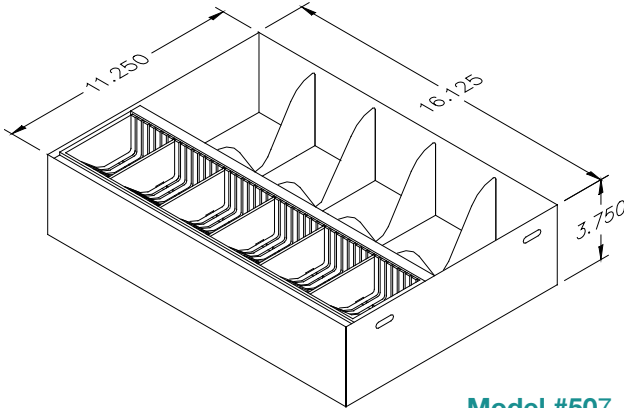

Shipping Weight:
8 lbs (3.6 kg)

Dimensions:

- Height:
3.75" (9.5 cm)
- Width:
16.125" (41 cm)
- Depth:
11.25" (28.6 cm)

Model #507

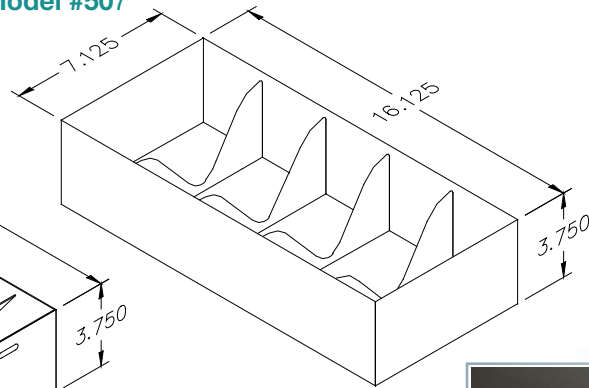

Model #508

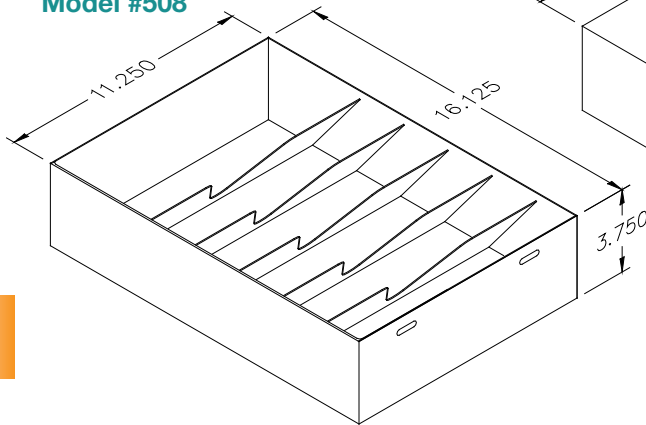

- All models come with a steel locking lid.

Compatible with



#10 Cash Drawer.



#20 Cash Drawer.