

UPC-30

Mobile Plasma Cart

CBM
design driven
manufacturing™

Holds up to 185 lbs
or a 60" flat panel

Standard Features

- Durable silver powder coat finish.
- Welded centre frame for ultimate stability.
- Two front locking casters.
- Simple bolt together assembly.
- Adjustable front shelf for DVD.



Optional



UPC-30-LTS
Side shelf for laptop
presentation



Front two locking
casters - back two
free rolling casters



sales@cbmmetal.com • www.cbmmetal.com • 800.387.4834

Audio Visual

UPC-30

Mobile Plasma Cart

UPC - 30

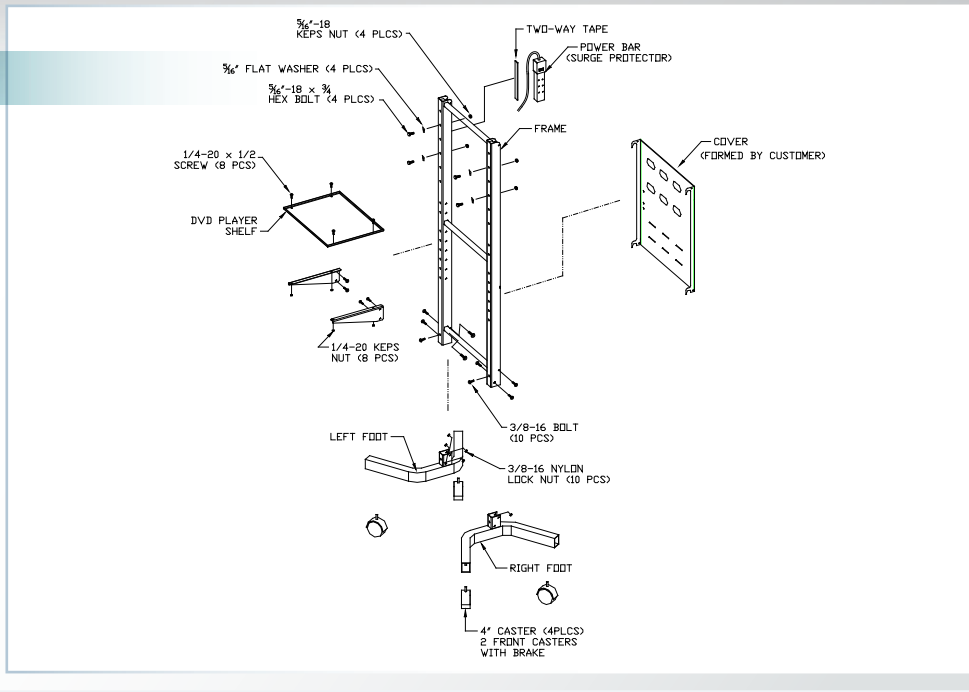

Mobile Plasma Cart

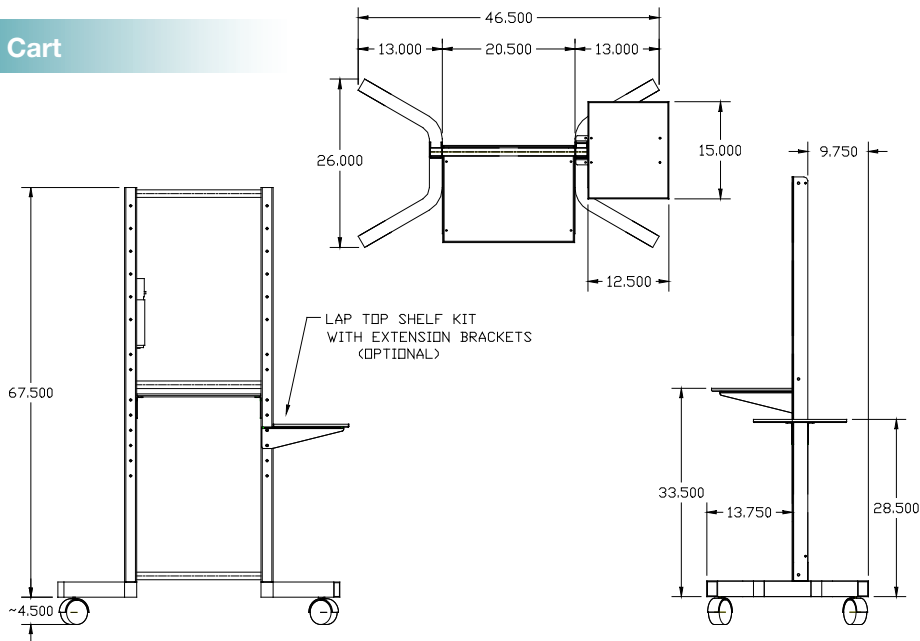

* 12 Month Full Satisfaction Guarantee *

CBM Ltd. guarantees its products against failure or defects for a period of one year from date of purchase. This warranty is void if any damage to the product is due to misuse, abuse, neglect, accident, improper installation, or any uses contrary to the instructions accompanying the product. The foregoing are the purchaser's exclusive remedies. CBM Ltd. assumes no liability for special or consequential damages. Replacement product may be obtained by returning the product, transportation charges prepaid, together with a receipt of purchase or other documents acknowledging the sale.

Specifications

Shipping weight:
85 lbs (38.6 kg)

Dimensions:
72" H x 46.5" W x 26" L (182.9 cm H x 118.1 cm W x 66 cm L)
Maximum load: 185 lbs (84 kg)

sales@cbmmetal.com • www.cbmmetal.com • 800.387.4834